

SHAPE ECO



SMALTATURA AL TITANIO



PROGRAMMA ASSISTENZA ITALIA



FUNZIONE ECO



PACCHETTO SICUREZZA



DISPLAY SMART



NANOMIX E TERMOSTATO BEST



ISOLAMENTO IN POLIURETANO PRIVO DI CFC E HCFC



DESIGN ITALIANO



- Design esclusivo
- Regolazione precisa e personalizzabile della temperatura
- Reset facile e immediato
- Isolamento di poliuretano di elevate dimensioni
- Valvola sicurezza testata a 8 bar
- Caldaia smaltata al titanio testata a 16 bar
- Flangia 5 bulloni

DATI TECNICI		50 V/5	80 V/5	100 V/5	50 H/5	80 H/5	100 H/5
Capacità	l	50	80	100	50	80	100
Potenza	kW	1,200	1,200	1,500	1,200	1,200	1,500
Voltaggio	V	230	230	230	230	230	230
Tempo di riscald. ($\Delta T=45^{\circ}\text{C}$)	h,min.	2,17	3,40	3,40	2,17	3,40	3,40
Temp. max d'esercizio	$^{\circ}\text{C}$	80	80	80	80	80	80
Dispersione termica a 65°C	kWh/24h	0,80	0,94	1,08	0,85	1,14	1,28
Pressione max d'esercizio	bar	8	8	8	8	8	8
Peso netto	kg	19	23,5	27	19	23,5	27
Protezione	IP	X4	X4	X4	X4	X4	X4

DIMENSIONI DI INGOMBRO

	50 V/5	80 V/5	100 V/5	50 H/5	80 H/5	100 H/5
A mm	570	775	927	570	775	927
B mm	379	584	736	164	331	483
C mm	191	191	191	172	191	191

MODELLO	50 V/5	80 V/5	100 V/5	50 H/5	80 H/5	100 H/5
CODICI	3605176	3605177	3605178	3605179	3605180	3605181

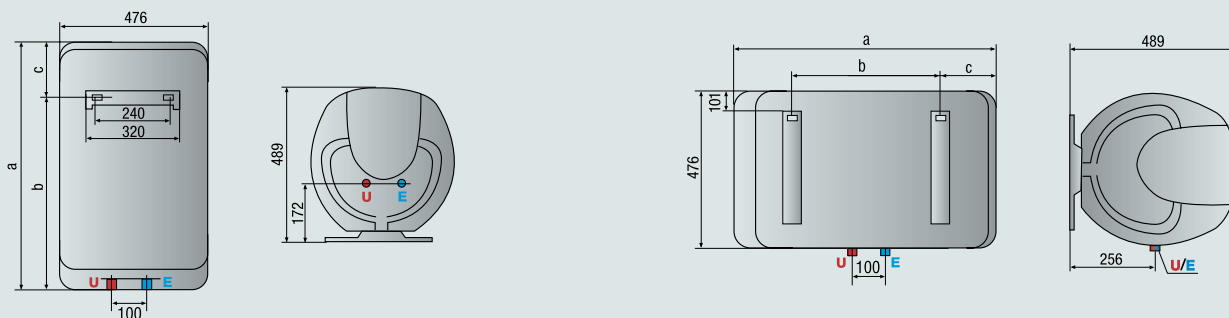

LEGENDA

E Entrata acqua fredda G 1/2"

U Uscita acqua calda G 1/2"